

ECOMAX

ERC Self-recuperative burner for gas

- For direct and indirect heating
- Economical, energy-saving operation by virtue of internal air preheating up to 650°C
- Uniform distribution of temperature by means of a high burner impulse
- 7 sizes from 25 to 500 kW
- Highly efficient with a ceramic burled tube recuperator or a cast steel ribbed tube recuperator.

Application



Self-recuperative burners ECOMAX are used for heating on either direct or indirect furnace systems in ON/OFF intermittent mode. The hot flue gases are fed through the ceramic or metallic heat exchanger, which is integrated in the burner, heating the additional supply of cold combustion air flowing in the opposite direction. The maximum achievable air preheat temperature amounts to approx. 650°C, depending on the application.

Direct heating

In conjunction with an eductor EJEK to extract the flue gases, the burner ECOMAX is used to save energy in a direct heating system without long hot air pipes requiring insulation.

Applications include heat treatment furnaces in the iron and steel industry and in the non-ferrous metal industry.

Indirect heating

Self-recuperative burners ECOMAX are used in conjunction with metallic or ceramic radiant tubes and ceramic segmented flame tubes SICAFLEX for indirect heating. Indirect heating equipment is used whenever the combustion gases are to be separated from the product, e.g. in heat treatment furnaces with inert gas atmospheres in the steel industry or when heat-treating aluminium.

Application examples

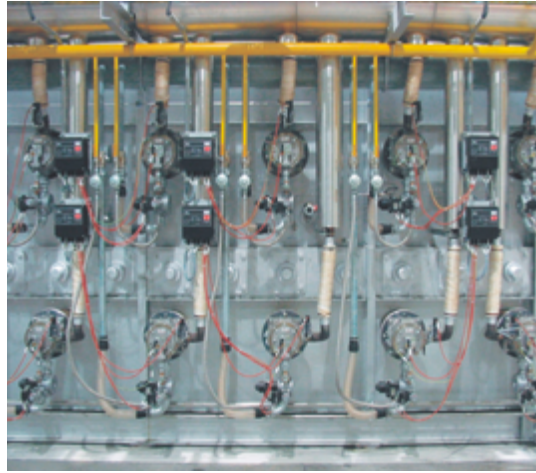

Roller hearth furnace



Bogie hearth furnace



Batch furnace

ECOMAX for direct heating systems

In direct heating systems, the burner ECOMAX is combined with a flue gas guide tube FGT Set..D for routing the flue gases through the furnace lining and a flue gas eductor EJEK.

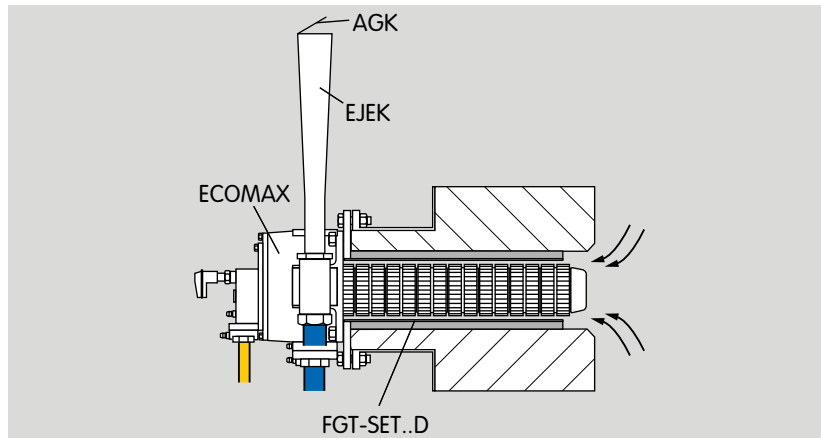

Eductor EJEK generates a negative pressure by forcing air through a centrally positioned nozzle and thus draws the flue gases out of the furnace chamber through the burner's heat exchanger. The motive air flow is adjusted on the basis of the negative pressure measured on the pressure tap between the burner and the motive air nozzle. A flue gas valve AGK on the eductor, which closes due to its own weight, minimizes backflow of hot flue gas from the furnace into the burner or infiltrated air being sucked into the furnace when the burner is switched off.

Flow rate control

For direct heating, flow rate control should be integrated in the system. The pressure loss in the recuperator depends on the furnace temperature. When the furnace temperature is increased (at a constant air supply pressure), the air flow rate drops. This change in the air flow rate is measured by the orifice and the VAH changes the gas volume accordingly to ensure that the air index (λ) on the burner is not dependent on the furnace temperature.

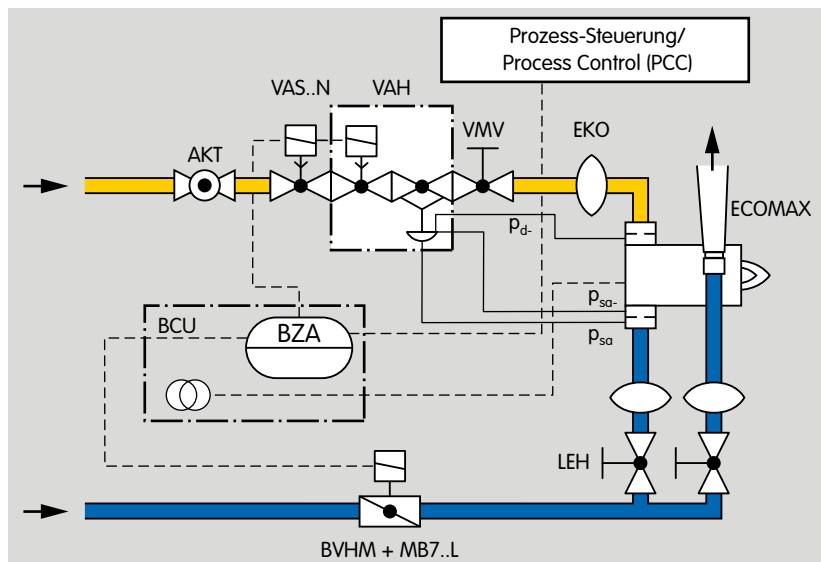

The ECOMAX is equipped with an integrated air orifice. This can be used for recording the air flow rate as a reference variable for the VAH. A separate upstream air orifice is then no longer required. The impulse line p_d - for gas is connected to the burner downstream of the integrated orifice so that the minimum gas pressure is sufficient.

Air/gas ratio control

If the system does not include flow rate control, temperature-dependent pressure losses in the burner are not compensated for. The air index λ drops with increasing furnace temperature (increasing air preheating). Therefore, in a cold furnace, an increased λ value is to be set to ensure sufficient excess air, even when the furnace temperature is at its maximum. A furnace at 1100°C with $\lambda = 1.1$ (approx. 2% O₂) requires a burner setting of approx. 4% O₂, for example, when the furnace is cold.

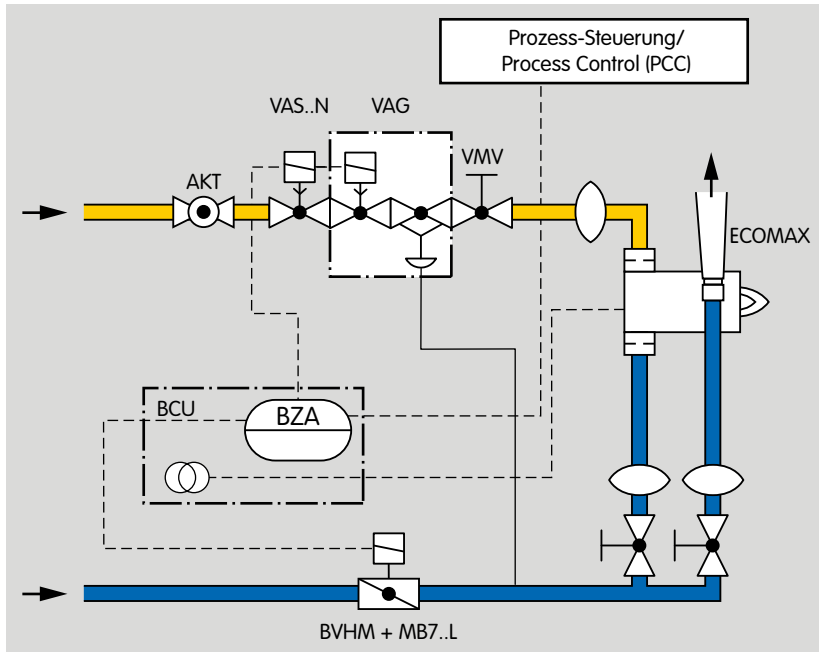

No pneumatic air/gas ratio control system

When there is no pneumatic air/gas ratio control system, slow opening gas valves and quick opening air control valves are to be used to ensure a safe burner start.

If there is no pneumatic air/gas ratio control system, the gas and air pressures must be controlled and monitored in the supply lines. Fluctuations in the supply pressure affect the burner capacity and the air index (λ).

Air flow monitoring is recommended as low air pressure protection (pursuant to EN 746-2 and ISO 13577-2) if the system does not include a pneumatic air/gas ratio control system. The ECOMAX is equipped with an integrated air orifice which can be used for this. The air flow monitoring system may also be used to monitor pre-purge.

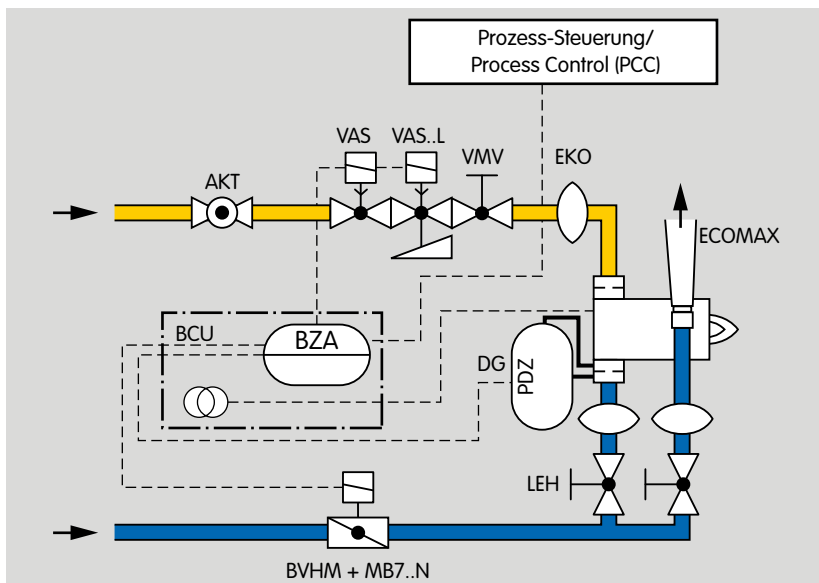

ECOMAX® for indirect heating systems

For indirect heating, various radiant tubes are used.

Single ended radiant tube

Indirect heating with the ECOMAX burner can be carried out using a metallic radiant tube SER-M or a ceramic radiant tube SER-C. A flame tube made of SICAFLEX elements is fitted inside the radiant tube to guide the flue gases. The flue gases are discharged via a flue gas connector FLUP.

The high outlet velocity of the flame causes a recirculation of the flue gases and thus:

- a reduction in NO_x emissions,
- a uniform radiant tube temperature.

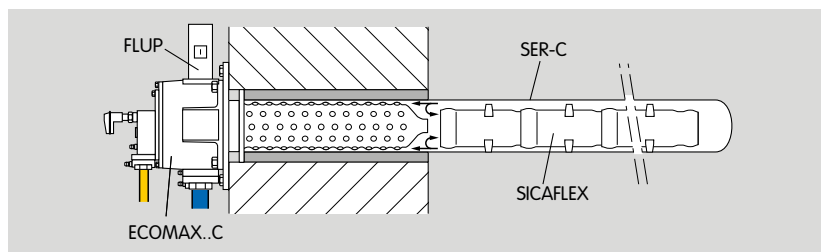
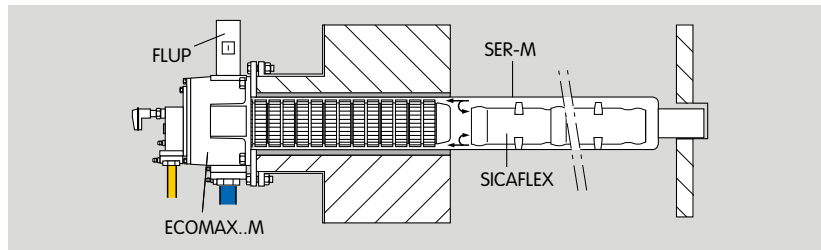

P and twin P radiant tube

P and twin P radiant tubes are used in some processes, for example in heat treatment systems for steel strip as an alternative to U or W radiant tubes. The new burner version ECOMAX..P with a special recuperator head is for use in P radiant tubes.

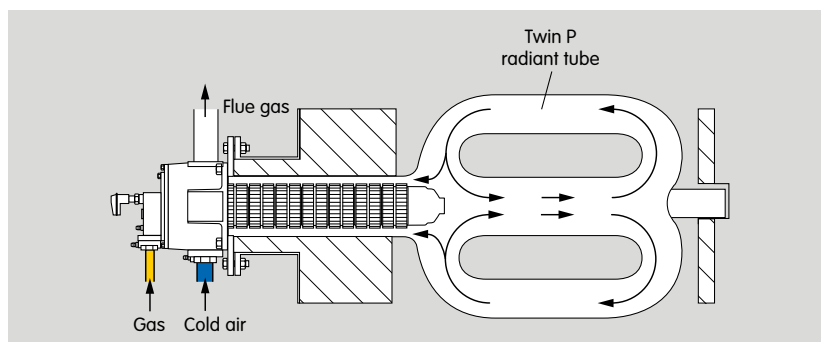
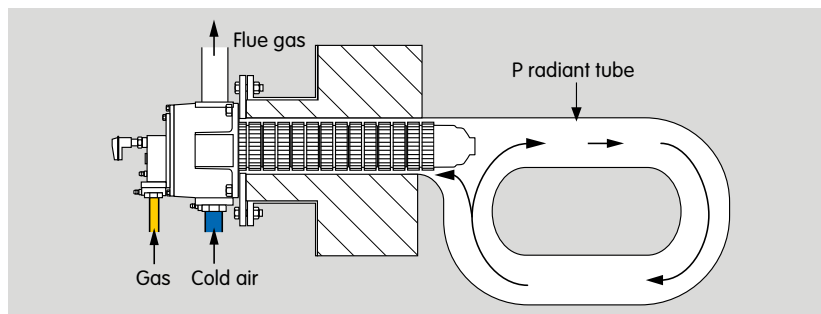

No pneumatic air/gas ratio control system

For indirect heating, slow opening gas valves and quick opening air control valves are to be used to ensure a safe burner start.

If there is no pneumatic air/gas ratio control system, the gas and air pressures must be controlled and monitored in the supply lines. Fluctuations in the supply pressure affect the burner capacity and the air index (λ).

A system which includes air flow monitoring is recommended to monitor pre-purge and as low air pressure protection (pursuant to EN 746-2 and ISO 13577-2). The ECOMAX is equipped with an integrated air orifice which can be used for this.

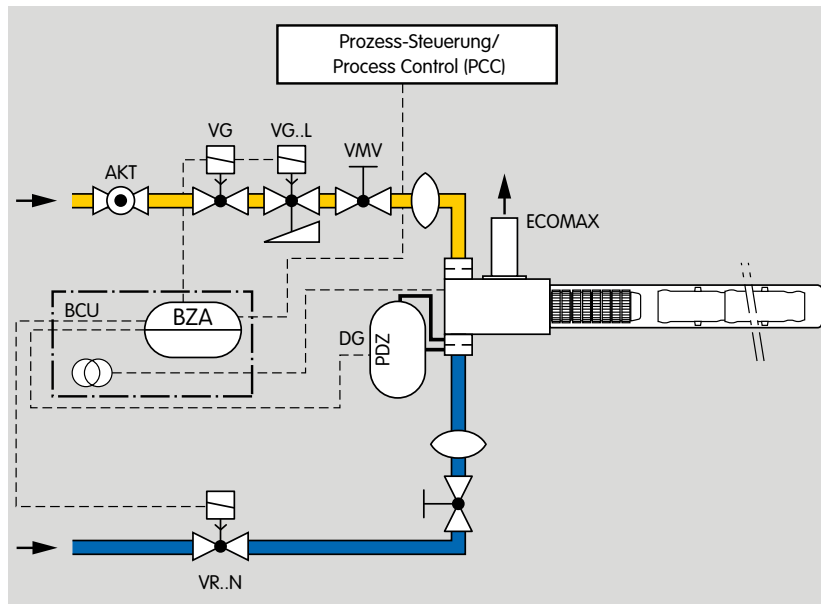

Air/gas ratio control

The pneumatic air/gas ratio control system ensures that changes in the air pressure in the air supply line are compensated for by controlling the gas pressure at the burner accordingly.

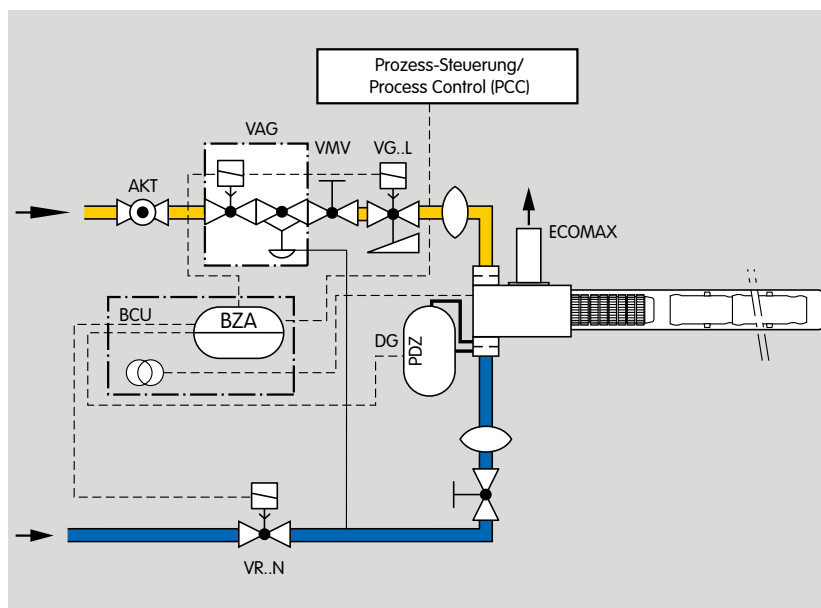

A system which includes air flow monitoring is also recommended to monitor pre-purge (pursuant to EN 746-2 and ISO 13577-2) even if there is a pneumatic air/gas ratio control system.

Type code

ECOMAX

Code	Description
ECOMAX	Self-recuperative burner for gas
0 – 6	Burner size
C	Ceramic burlled tube recuperator made of SiSiC
M	Cast steel ribbed tube recuperator
P	Cast steel ribbed tube recuperator for P radiant tube
F	Flat tube recuperator, metallic
E	Special recuperator version
395 – 695	Recuperator length in mm
-S -M ¹⁾	Standard flame menox [®] low NO _x operation
B D G L ¹⁾	Gas type ²⁾ : natural gas coke oven gas LPG LCV gas
/D-	For direct heating with eductor
/R-	For radiant tube heating without eductor
/V-	For radiant tube heating with VAH
/E-	Burner with customized orifices
/nnn-	Burner construction stage X for nnn kW
/N-	Burner without orifices
(1 – 99)	Burner head identifier
X, A, B, ...	Construction stage
-	The following features differ from the standard version:
K	Additional cooling air connection for increased furnace cooling
A	Electrode made of Kanthal APM
T	NPT connections
S	SICAFLEX spacer
W	Air connection without intermediate flange
Z	Special version

¹⁾ On request.

²⁾ Other types of gas on request.

EJEK

Code	Description
EJEK	Flue gas eductor
0 – 6	Size for ECOMAX 1 – 6
-Kxxx	Axis spacing K in mm
-Myyy	Height M in mm
-Tzzz*	Distance T in mm
-H -V	Burner installation position: horizontal vertical
-3 -9	Installation on the burner ^{**} : right-hand side left-hand side
-F5 to -F15 -R5 to -R15	Eductor angle in °: pointing towards furnace pointing away from furnace
-AGK	With flue gas valve
-HT ^{***}	High temperature version
-A -B	Construction stage
-S	Standard dimension

* If "none", this letter is omitted.

** Only required for special dimension Tzzz.

*** HT version for ECOMAX..C.

FLUP

Code	Description
FLUP	Flue gas connector
0 1/2 3 4/5	For ECOMAX 0 – 5
-32 to -100	Nominal size
D F	Pipe connector Flange to ISO 7005
-Kxxx	Axis spacing K in mm
-Myyy	Installation height M in mm
-Tzzz*	Distance T in mm
-H -V	Burner installation position: horizontal vertical
-0 -3 -9	Installation on the burner ^{**} : top right-hand side left-hand side
-C -A	Measuring port with sealing clip Threaded pressure tap with cap
-HT	High temperature version
-A -B	Construction stage
-S	Standard dimension

* If "none", this letter is omitted.

** Only required for special dimension Tzzz.

Technical data

Gas supply pressure and air supply pressure each depend on the use and gas type (gas and air pressures: see burner diagrams at www.docuthek.com – registration required).

Type of heating: direct with eductor or indirect in radiant tube.

Control type: On/Off.

Adjusting range: 60% to 100%.

Flame velocity: approx. 130 to 170 m/s.

Flame control: direct ionization control (UV control as an option).

Ignition: direct spark ignition.

Burner	Recuperator	Max. flue gas temperature at recuperator inlet
ECOMAX..C	Ceramic (SiSiC)	1250°C*
ECOMAX..M	Cast steel	1150°C
ECOMAX..F	Metallic	1050°C

* We advise against use in forging and heating furnaces, in which raw materials are heated.

Burner	Capacity [kW]	Flame length [mm]*
ECOMAX 0	25	300
ECOMAX 1	36	300
ECOMAX 2	60	400
ECOMAX 3	100	450
ECOMAX 4	180	800
ECOMAX 5	250	800
ECOMAX 6	500	1000

* Visible range for natural gas operation in the open air, max. connection rating and air index 1.15.

The visible flame diameter is 0.3 to 0.5 times that of the burner Ø B for natural gas operation in the open air, max. connection rating and air index 1.15.

REACH Regulation

Information pursuant to REACH Regulation No. 1907/2006, Article 33.

Insulation contains refractory ceramic fibres (RCF)/aluminium silicate wool (ASW).

RCF/ASW are listed in the Candidate List of the European REACH Regulation No. 1907/2006.

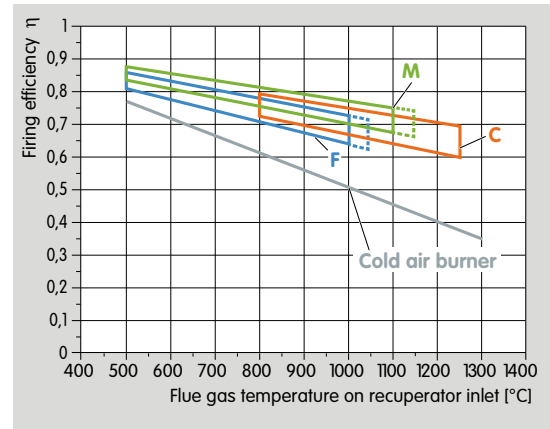

Maintenance

Twice per year, but if the media are highly contaminated, this interval should be reduced.

Contact

www.kromschroeder.com → Process Heat → Sales
 Elster GmbH
 Strothweg 1 · 49504 Lotte (Büren)
 Germany
 Tel. +49 541 1214-0
hts.lotte@honeywell.com
www.kromschroeder.com

Technical
 Information bulletin
 for this product

www.docuthek.com
 Search term: ECOMAX

We reserve the right to make technical modifications in the interests of progress.
 Copyright © 2018 Elster GmbH
 All rights reserved.

Honeywell
kromschroeder