



BCU 480



Burner control units

- For pilot and main burners in intermittent or continuous operation
- Replace the local control cabinet
- Flame control by UV, ionization or a further option of using the furnace chamber temperature
- Display of the program status, unit parameters and flame signal; Manual mode for burner adjustment and for diagnostic purposes
- Visualization and adaptation to the specific application via the PC programming and diagnostic software BCSoft to simplify logistics management
- Air valve control relieves the furnace control
- Optional PROFIBUS DP interface
- EC type-tested and certified
- Certified for systems up to SIL 3 and compliant with PL e

Application

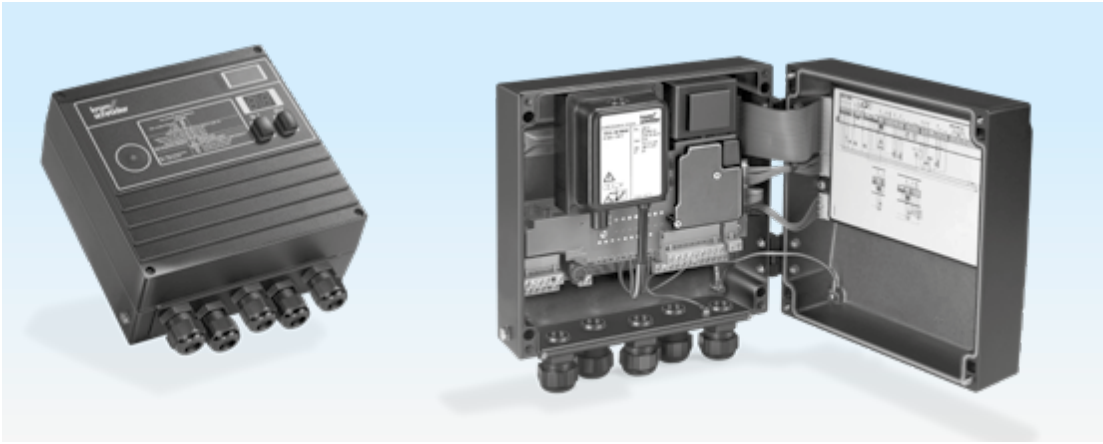

The BCU unites the functionally inter-related components of automatic burner control unit, ignition transformer, Manual/Automatic mode and display of operating and fault statuses in a compact metal housing.

The burner control units BCU 480 control, ignite and monitor gas burners for intermittent or continuous operation. As a result of their fully electronic design, they react quickly to various process requirements and are therefore suitable for frequent cycling operation.

They can be used for industrial burners of unlimited capacity which are ignited by pilot burners. Pilot and main burners may be modulating or stage-controlled. The BCU 480 monitors pilot and main burners independently. The pilot burner can burn permanently or be switched off. The BCU is installed near the burner to be monitored.

On industrial furnaces, the BCU reduces the load on the central furnace control by taking over tasks that only relate to the burner, for example it ensures that the burner always ignites in a safe condition when it is restarted.

The air valve control assists the furnace control for cooling, purging and capacity control tasks.

The program status, the unit parameters and the level of the flame signal can be read directly from the unit. The burner can be controlled manually for commissioning and diagnostic purposes.

If the local requirements on the burner control unit change, the PC software "BCSoft" can be adjusted to the unit parameters of the application by using the optical interface.

The service personnel is supported by a convenient visualization system of the input and output signals and the error history.

The new power management scheme reduces installation and wiring costs. The power for the valves and ignition transformer is supplied via the power supply of the BCU, protected by a replaceable fine-wire fuse.

The conventional wide-spread systems used in industrial furnace and kiln construction require bridging of large distances for signal processing. The optionally available BCU..B1 for connection to the PROFIBUS DP fieldbus is equipped for this purpose.

As a standardized fieldbus system, the PROFIBUS DP considerably reduces development, installation and commissioning costs compared to conventional wiring.

The use of a standard bus system offers massive benefits compared to manufacturer-specific bespoke solutions. Time-tested hardware components, standardized connection methods and a series of tools of bus diagnostics and optimization are available on the market from a whole range of manufacturers. The widespread use of the system ensures that the planning and service personnel are very familiar with how the system operates and how to handle it and can therefore operate the system efficiently.



Bogie hearth forging furnace in the metallurgical industry

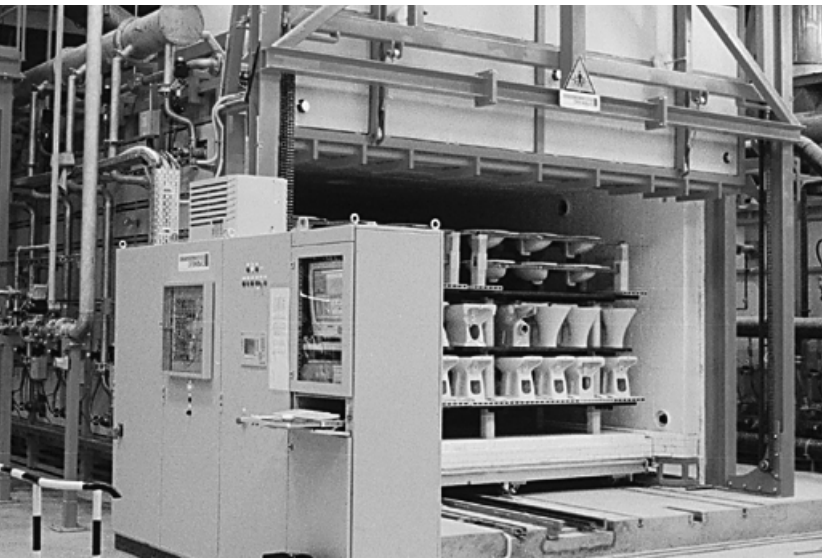

Intermittent shuttle kiln in the ceramics industry



Walking beam furnace with overhead firing

Examples of application

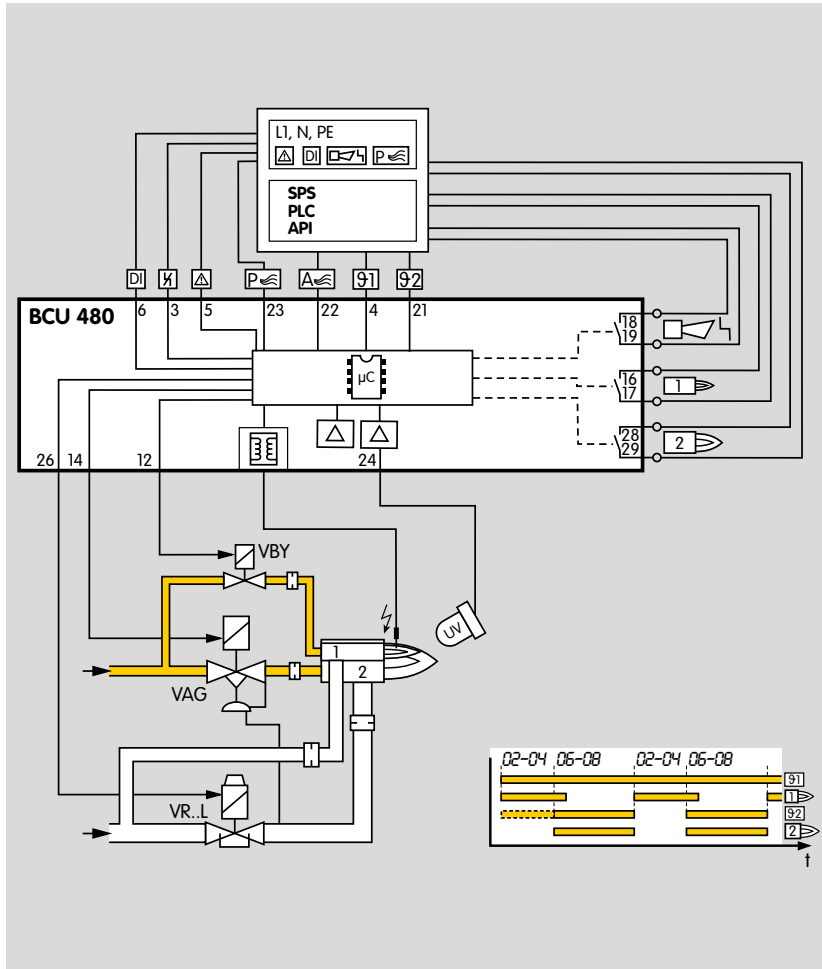

Stage-controlled main burner with alternating pilot burner

Control:
Main burner ON/OFF.

The main burner can be started with reduced capacity after the operating signal from the pilot burner has been detected. The pilot burner is switched off automatically after the main burner has started up. When the main burner is switched off, the pilot burner automatically switches on again. This reduces the main burner start-up time.

A UV sensor monitors the flame signal from pilot and main burners. UV sensor UVD 1 is used for continuous operation, UV sensor UVS for intermittent operation.

The BCU provides the cooling and purging processes.

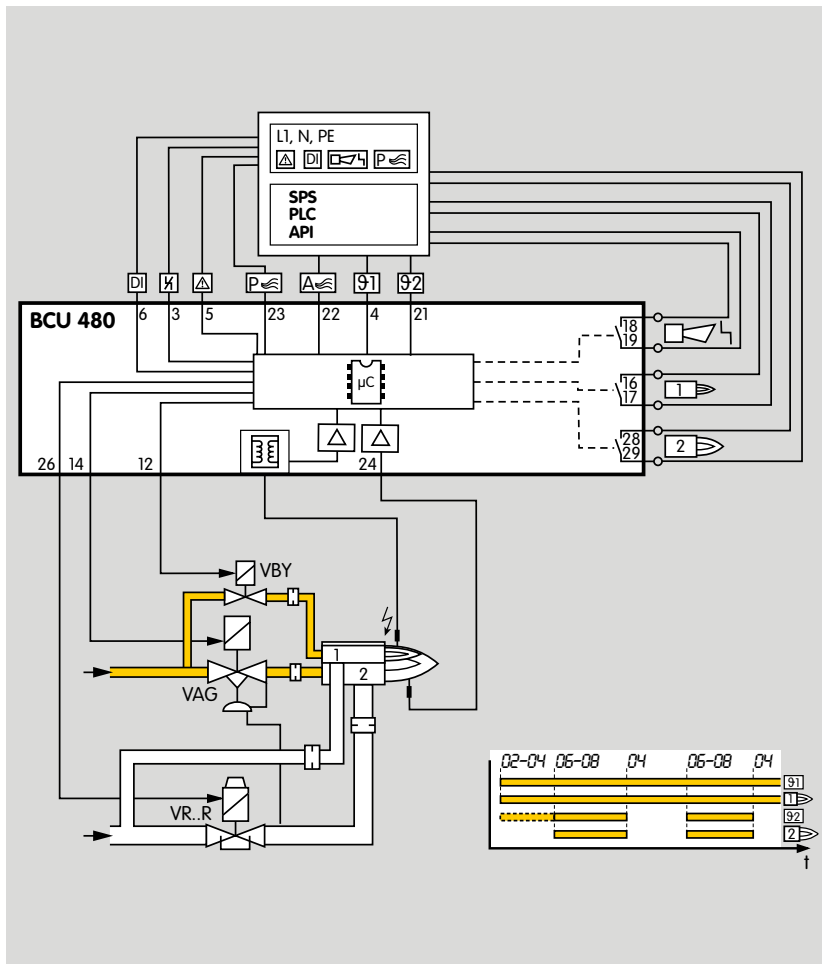

Stage-controlled main burner with permanent pilot burner

Control:
Main burner ON/OFF.

The main burner can be started with reduced capacity after the operating signal from the pilot burner has been detected. Pilot and main burners can be operated simultaneously. This reduces the time required by the main burner for starting up.

The BCU provides the cooling and purging processes.

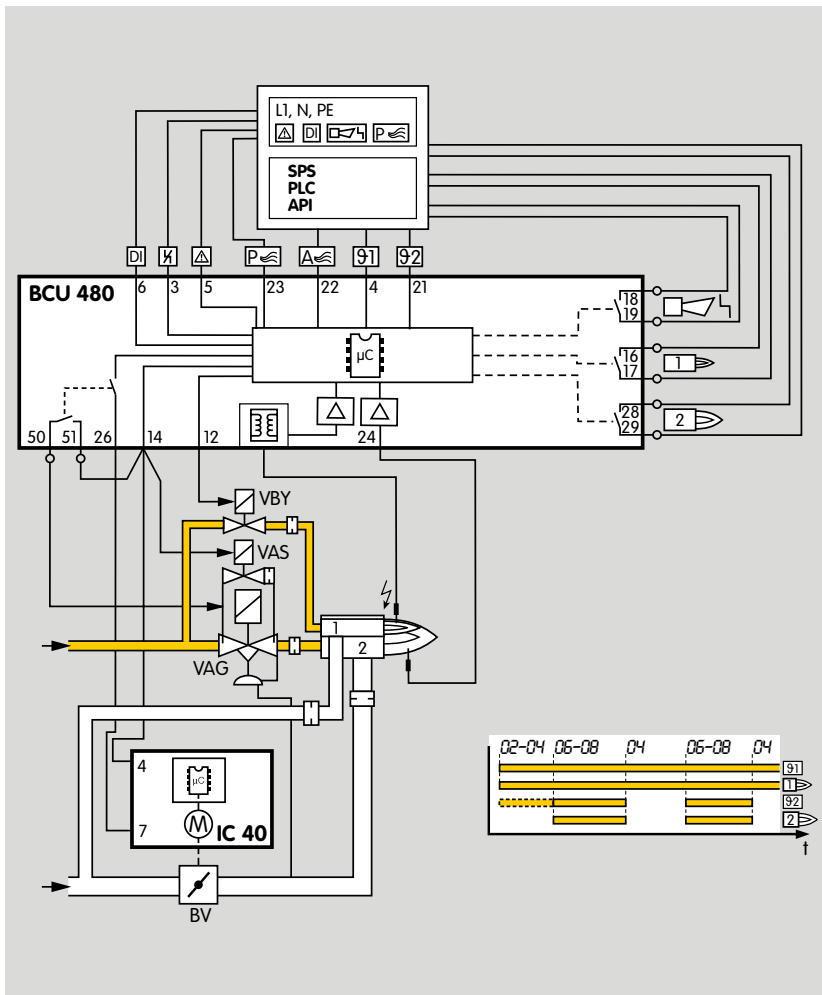

Two-stage-controlled main burner with permanent pilot burner

Control:

Main burner ON/OFF with ignition via bypass.

The main burner can be started at low-fire rate after the operating signal from the pilot burner has been detected. When the operating state is reached, the BCU issues the Enable signal for the maximum burner capacity. Pilot and main burners can be operated simultaneously. This reduces the time required by the main burner for starting up.

The BCU provides the cooling and purging processes.

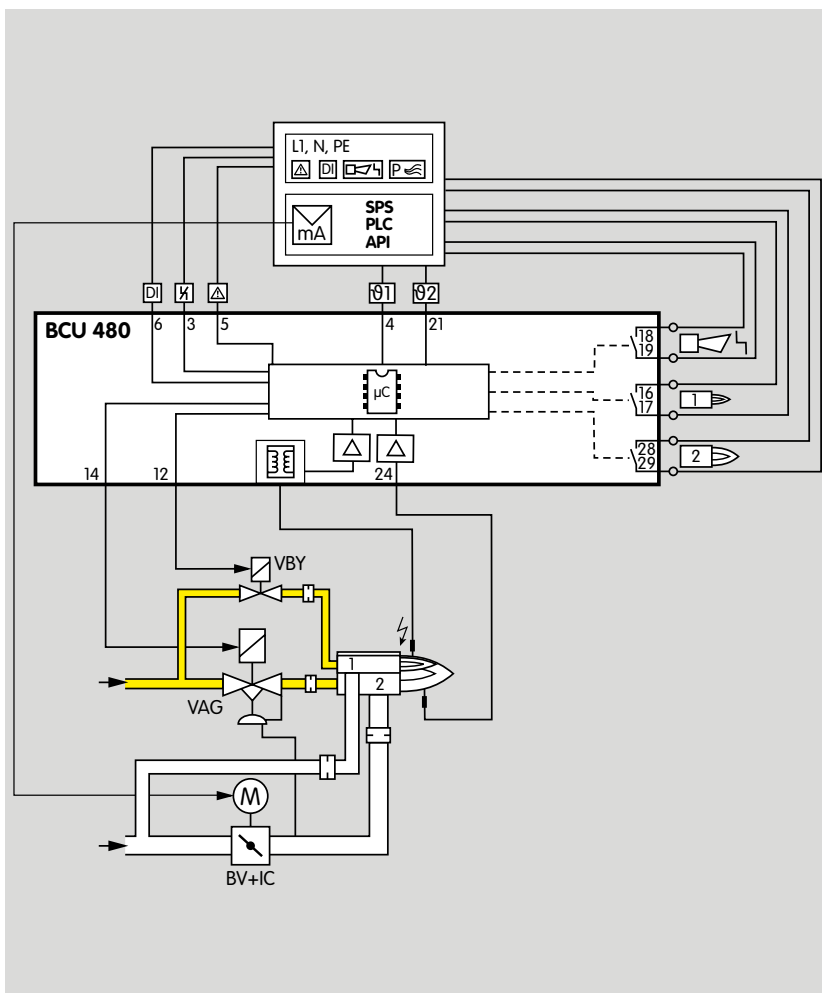

Modulating-controlled burner

Control:

Main burner continuous.

The butterfly valve for air is moved to ignition position in order to start the main burner. The main burner can be started at low-fire rate after the operating signal from the pilot burner has been detected. The control system controls the burner capacity via the butterfly valve for air after the operating state has been signalled. Pilot and main burners can be operated simultaneously. This reduces the time required by the main burner for starting up.

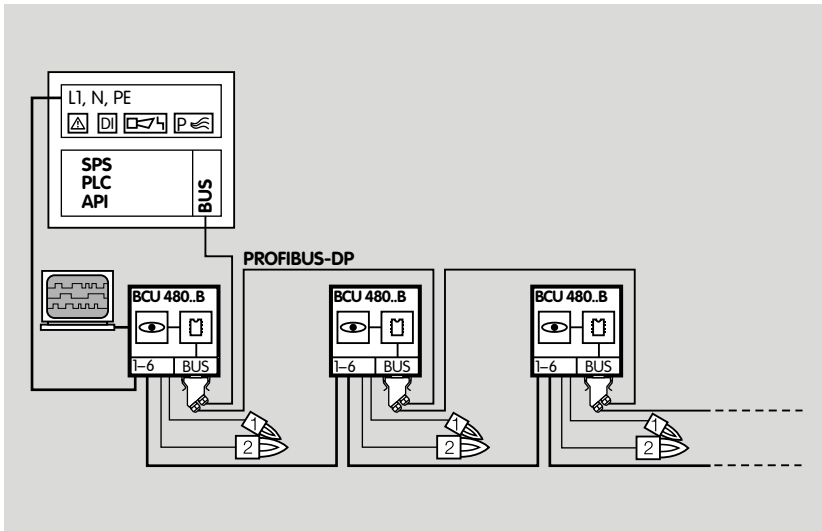

BCU 480..B1 for PROFIBUS DP

The bus system transfers the control signals for starting, resetting and for controlling the air valve from the control system to the BCU 480..B1. In the opposite direction, it sends operating status, the level of the flame signals and the current program status.

Control signals that are relevant for safety, such as the safety interlocks, purge (optional) and digital input, are transferred independently of the bus communication by separate cables.

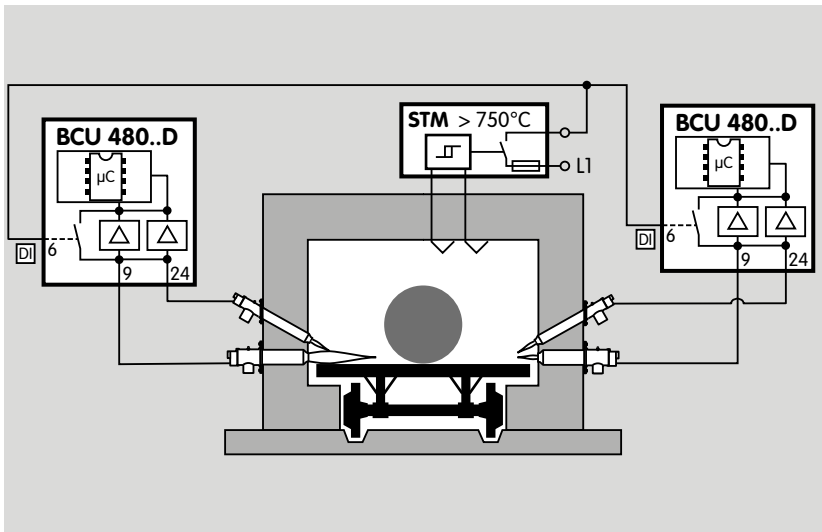

BCU 480..D:

High temperature equipment

Indirect flame control using the temperature. During the start-up process, as long as the wall temperature is below auto ignition temperature, the flame must be controlled by conventional methods. When the working temperature has exceeded 750°C, the safety temperature monitor (STM) takes over the indirect flame control.

Selection

	T	-3	-5	-10	/3	/5	/1	/2	L	5	15	25	W	R	1	2	3	8	GB ¹⁾	P ²⁾	D2	D3	S2	S3	/2	/3	U	C	B1	/1	E1	
BCU 480	●	●	●	●	●	●	●	●	●	○	○	○	○	○	○	○	○	○	○	○	○	○	○	○	○	○	○	○	○	○	○	○

Order example

BCU 480-5/3/1LW3GBCE1

● = standard, ○ = available. ¹⁾ Not available for BCU..T. ²⁾ Not in conjunction with PROFIBUS DP (BCU..B1).

Technical data

Mains voltage:

230 V AC, -15/+10%, 50/60 Hz,

115 V AC, -15/+10%, 50/60 Hz,

for grounded and ungrounded mains.

Inherent consumption: approx. 9 VA plus inherent consumption of the integrated ignition transformer [50/60 Hz].

Voltage to inputs and valves = mains voltage.

Signal and control line: max. 2.5 mm² (AWG 14).

Cable for burner ground/PE wire:

4 mm² (AWG 12).

Cable gland:

5 cable glands with multiple seal inserts for cable diameters of up to 7 mm,

BCU..P: with 2 cable glands and an industrial chassis plug. Each BCU is supplied for two cable glands with one seal insert each for cable diameters between 7 – 12 mm.

Input voltage of signal inputs:

Rated value	115 V AC	230 V AC
Signal "1"	80 – 126.5	160 – 253
Signal "0"	0 – 20	0 – 40
Frequency	50/60 Hz	50/60 Hz

Input current of signal inputs:

Signal "1": typ. 2 mA

Output current:

max. 1 A, $\cos \varphi = 1$, for the valve outputs (or SRC outputs),

but total current for valves and ignition transformer: max. 2.5 A

Fail-safe inputs and outputs:

All the inputs and outputs marked "■" (see connection diagrams) may be used for safety tasks.

Flame control with UV sensor or ionization sensor.

Flame signal for ionization control: 1 – 28 μ A,

UV control: 1 – 35 μ A.

For intermittent or continuous operation.

Maximum length of ignition cable with integrated electronic ignition: 5 m (16.4 ft).

Maximum length of ionization/UV cable: 50 m (164 ft).

Fuses in unit:

F1: 3.15 A, slow-acting, H, pursuant to IEC 127-2/5.

Fuse for protecting the safety-relevant ignition, valve 1, valve 2 and air valve outputs (terminals 7, 12, 14 and 26): 5 A, slow-acting, not replaceable.

F3 (only for BCU..A, BCU..C and BCU..U):

3.15 A, slow-acting, H, pursuant to IEC 127-2/5.

Operation and fault signalling contacts:

Signalling contact for mains voltage,

max. 2 A, 253 V,

not internally fused.

Number of operating cycles:

Relay outputs: 250,000 pursuant to EN 298,

Mains switch: 1,000,

Reset/Information button: 1,000.

Ambient temperature:

-20 to +60°C (-4 to +140°F),

climate: no condensation permitted.

Enclosure: IP 54 pursuant to IEC 529.

Weight:

approx. 5 kg (11 lb) depending on version.

Ignition transformer	Input			Output	
	V AC	Hz*	A*	V	mA*
TZI 5-15/100W	230	50 (60)	0.45 (0.35)	5000	15 (11)
TZI 7-25/20W	230	50 (60)	1.1 (0.8)	7000	25 (18)
TZI 7,5-12/100W	230	50 (60)	0.6 (0.45)	7500	12 (9)
TZI 7,5-20/33W	230	50 (60)	0.9 (0.7)	7500	20 (15)
TZI 5-15/100R	115	50 (60)	0.9 (0.7)	5000	15 (11)
TZI 7-25/20R	115	50 (60)	2.2 (1.6)	7000	25 (18)
TZI 7,5-12/100R	115	50 (60)	1.2 (0.9)	7500	12 (9)
TZI 7,5-20/33R	115	50 (60)	1.8 (1.35)	7500	20 (15)

* Values in () apply to 60 Hz.

BCU..B1

External fuse: 12 A per zone.

PROFIBUS DP

Manufacturer ID: 0x05DB.

ASIC type: SPC3.

SYNC- and FREEZE-capable.

Baud rate detection: automatic.

Min. cycle time: 0.1 ms.

Diagnostic bytes: 6 (DP Standard).

Parameter bytes: 7 (DP Standard).

Safety-specific characteristic values

In the case of ionization control, suitable for Safety Integrity Level	SIL 3
Diagnostic coverage DC	92.7%
Type of subsystem	Type B to EN 61508-2, 7.4.3.1.4
Mode of operation	High demand mode pursuant to EN 61508-4, 3.5.12
Mean probability of dangerous failure PFH _D	1.92×10^{-8} 1/h
Mean time to dangerous failure MTTF _d	$MTTF_d = 1 / PFH_D$
Safe failure fraction SFF	98.8%

The specified values apply for the combination with ionization electrode (sensor) and a unit of the BCU 400 series. No characteristic values are available for flame control with UV sensor.

Relationship between the Performance Level (PL) and the Safety Integrity Level (SIL)

PL	SIL
a	-
b	1
c	1
d	2
e	3

Pursuant to EN ISO 13849-1:2006, Table 4, the BCU can be used up to PL e.

Max. service life under operating conditions:
20 years after date of production.

Technical Information bulletin for this product

www.docuthek.com

Search term: BCU 480

Contact

www.kromschroeder.com → Process Heat → Sales

Elster GmbH

Strotheweg 1 · 49504 Lotte (Büren)

Germany

Tel. +49 541 1214-0

hts.lotte@honeywell.com

www.kromschroeder.com

We reserve the right to make technical modifications in the interests of progress.
Copyright © 2018 Elster GmbH
All rights reserved.

